

Customer : \_\_\_\_\_

# SPECIFICATION

Type \_\_\_\_\_ : DIELETRIC FILTERPart Number : AMOBP 2332 P02 - BDate \_\_\_\_\_ : Feb. 15 ., 2005

Rev. No	Issue	Rev. Page	Rev. Date	Check

DRAWN	DESIGNED	CHECKED	APPROVED

## **AMOTECH CO., LTD**

5B 1L, 617 NAMCHON-DONG, NAMDONG-GU, INCHEON, KOREA

TEL : 82-32-821-0363 FAX : 82-32-811-0283

# SPECIFICATION

Date : 2005. 2. 15

## 1. SCOPE

This specification covers the characteristics of the dielectric band pass filter for the 2.3GHz XM-Band Digital Radio System.

## 2. MODEL NUMBER

Part No. : AMOBP 2332 P02 - B

## 3. COMPOSITION AND MATERIALS

Resonators : Dielectric Materials

Number of Poles : 2 poles

Input/Output Terminals : Ag plated pattern

## 4. ELECTRICAL SPECIFICATIONS

No.	ITEM	SPECIFICATION	Typical data
4-1	Center Frequency (fo)	2332.5 MHz	2332.5 ±0.5MHz
4-2	Pass Bandwidth (BW)	fo +/- 12.5 MHz	25MHz ±0.5MHz
4-3	Insertion Loss (IL) in BW	3.0 dB Max	Avg 1.8 dB (B.W)
4-4	Ripple	1.0 dB Max	Avg 0.3 dB (B.W)
4-5	VSWR in BW	2.0 Max	Avg 1.31 (B.W)
4-6	Attenuation (Absolute Values)		
	at 2232.5MHz (fo-100MHz)	24.0dB Min	Avg 32.0dB Min
	at 2432.5MHz (fo+100MHz)	18.0dB Min	Avg 22.0dB Min
4-7	Input Power	1 Watt Max	1.5 Watt
4-8	Input/Output Impedance	50 ohms	45 ~ 55 ohms
4-9	Operation Temperature Range	-30℃ ~ +85℃	-40℃ ~ +95℃
4-10	Testing JIG	SMA JIG(7336)	

## 5. ENVIRONMENTAL SPECIFICATIONS

\*\* Operation conditions : Temperature range :  $-40\text{ }^{\circ}\text{C} \sim +90\text{ }^{\circ}\text{C}$

Humidity range :  $45 \sim 85\text{ \% RH}$

The device should satisfy the electrical characteristics specified in paragraph 4 after the following tests. Measurements should be done after putting in the typical condition ( $20\sim 30\text{ }^{\circ}\text{C} / 55\sim 75\text{ \% RH}$ ) for 2 hours minimum.

### 5-1. Temperature Characteristics

The device should satisfy the electrical characteristics specified in paragraph 4 at the temperature range of  $-40\text{ }^{\circ}\text{C} \sim +90\text{ }^{\circ}\text{C}$ .

### 5-2. Heat Proof

The device should satisfy the electrical characteristics specified in paragraph 4 after exposed to the Temperature  $90 \pm 2\text{ }^{\circ}\text{C}$  for 96 hours.

### 5-3. Cold Proof

The device should satisfy the electrical characteristics specified in paragraph 4 after exposed to the temperature  $-40 \pm 2\text{ }^{\circ}\text{C}$  for 96 hours.

### 5-4. Moisture Proof

The device should satisfy the electrical characteristics specified in paragraph 4 after exposed to the temperature  $40 \pm 2\text{ }^{\circ}\text{C}$  and the humidity  $95\text{ \% RH}$  for 96 hours.

### 5-5. Vibration

The device should satisfy the electrical characteristics specified in paragraph 4 after applied to the vibration of 10 to 50 Hz with amplitude of 1.5 mm & sw of 1min for 2 hours each of x, y and z directions.

### 5-6. Drop Shock

The device should satisfy the electrical characteristics specified in paragraph 4 after dropped onto the hard wooden board from the height of 50 cm for 3 times toward each of x, y and z directions except the terminal direction.

### 5-7. Solder Heat Proof

The device should satisfy the electrical characteristics specified in paragraph 4 after reflowed at  $260 \pm 5\text{ }^{\circ}\text{C}$  for  $10 \pm 1$  seconds.

## 6. SOLDERING CONDITIONS

The device should satisfy the electrical characteristics specified in paragraph 4 after reflowed on the following condition.

### 6.1) Allowable Temperature.

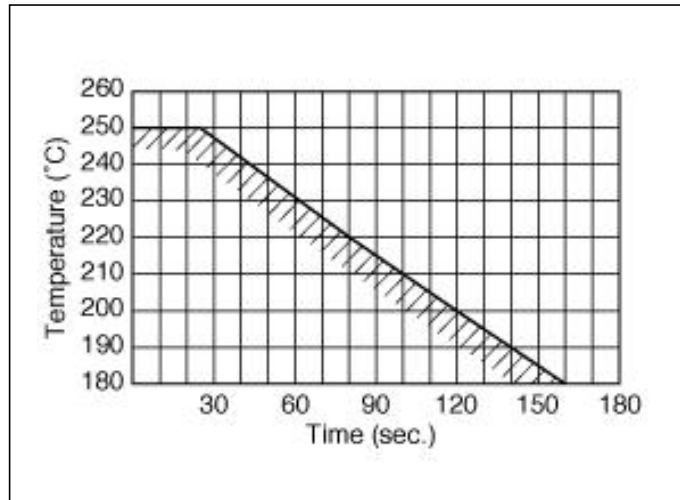

### 6.2) Reflow Condition.

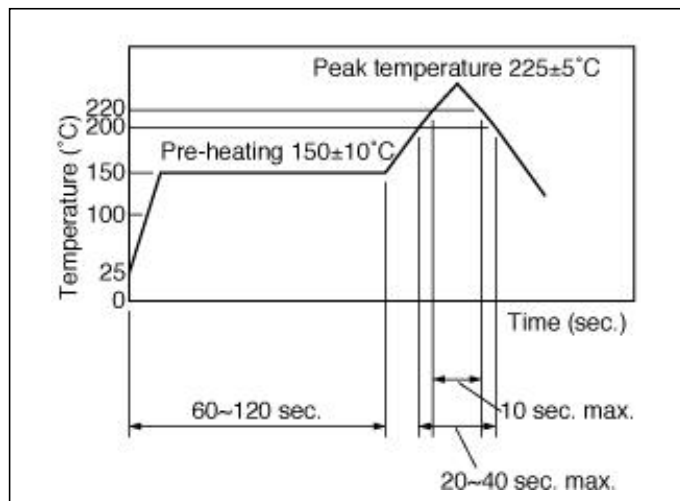

**7. DIMENSION**

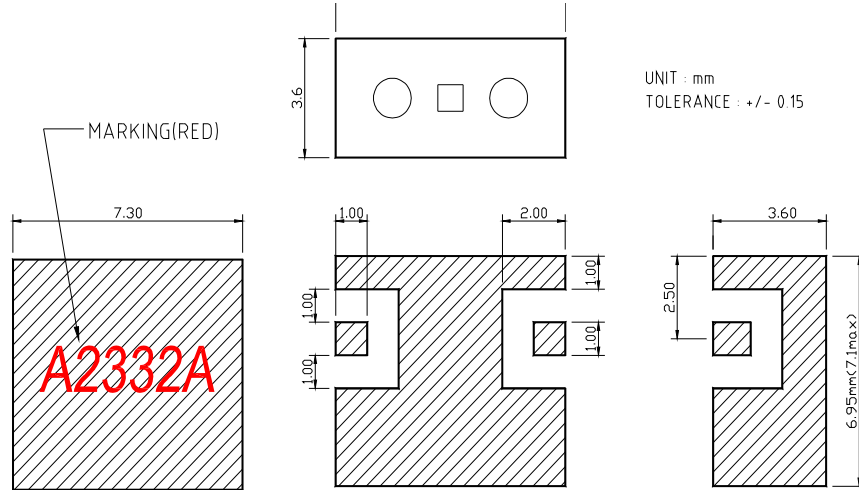

**8. RECOMMENED REFLOW PATTERN**

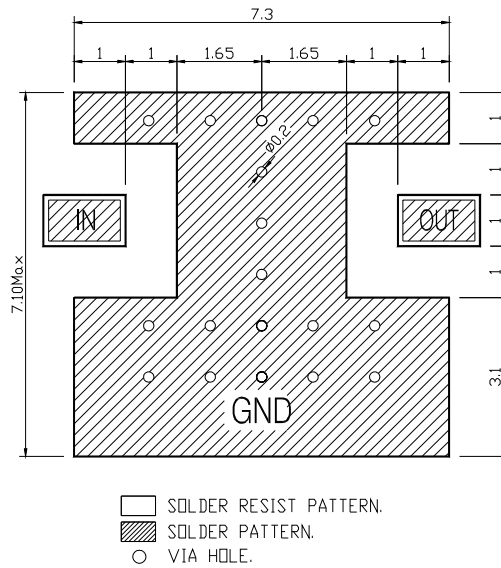

### 9. PACKAGES

I Taping Reel Packages Pieces / Tape : 1,500 Pcs. \* Reel: diameter – 330mm

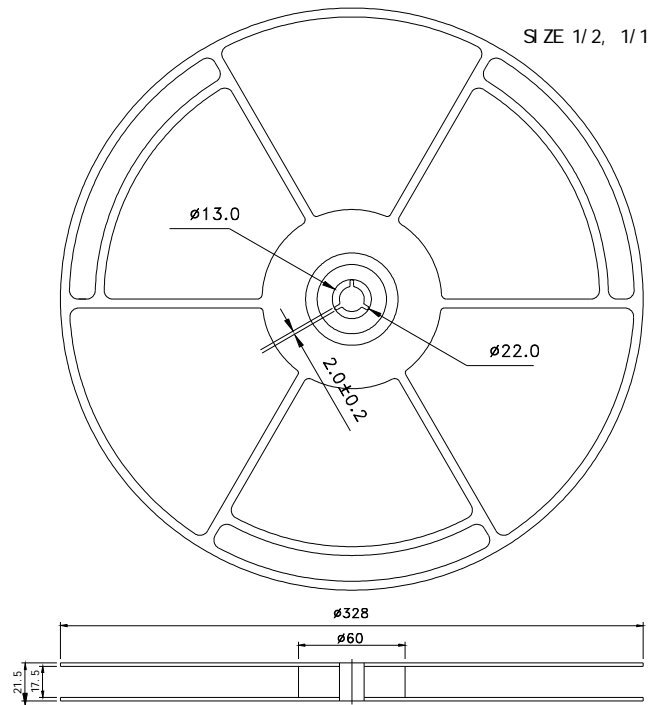

I Embossed Carrier Tapes.(CART16-01)

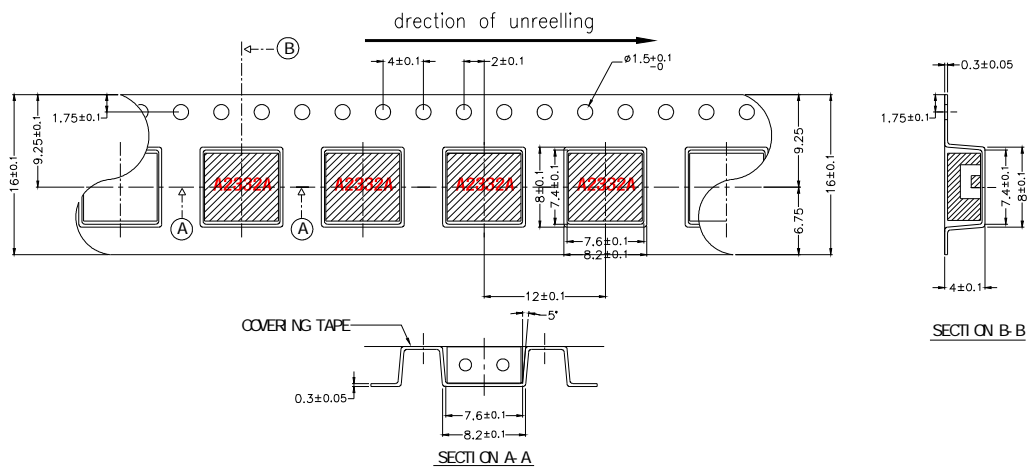

10 . Typical Characteristic Curve.

